

SERIES 2 POST & PANEL:

SERIES 2 2" SQUARE POST
PART #1100

SERIES 2-3 REVEAL
PART #1200

SERIES 2 SLIDE BODY
PART #1110

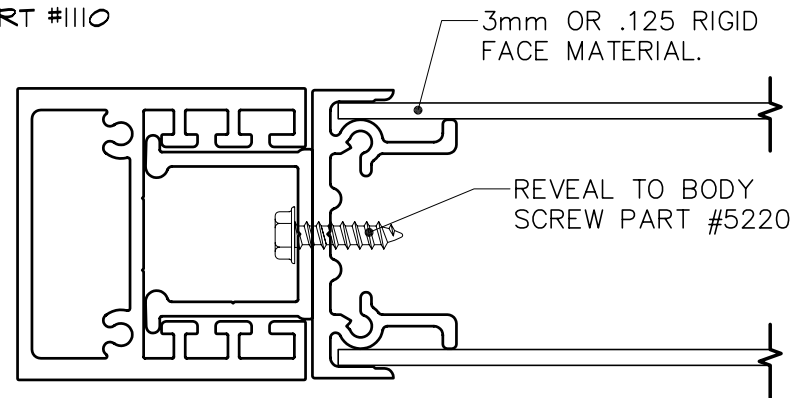

0" REVEAL POSITION

SCALE : 3/4" = 1"

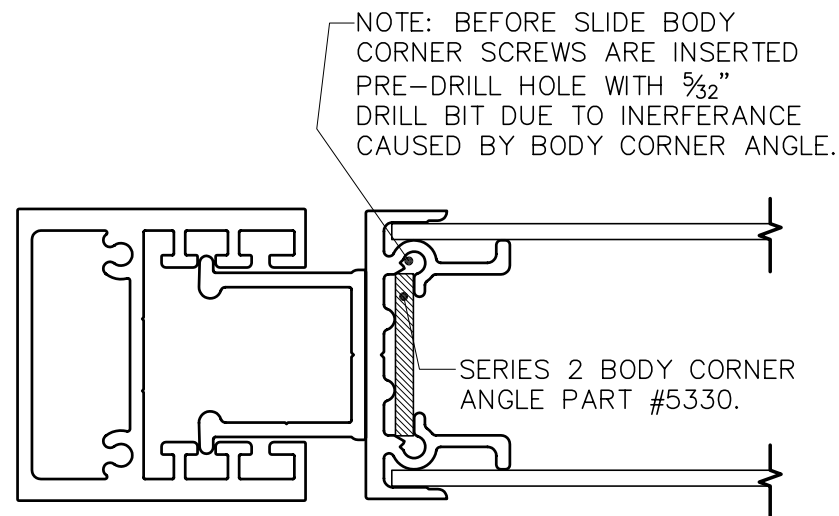

3/8" REVEAL POSITION

SCALE : 3/4" = 1"

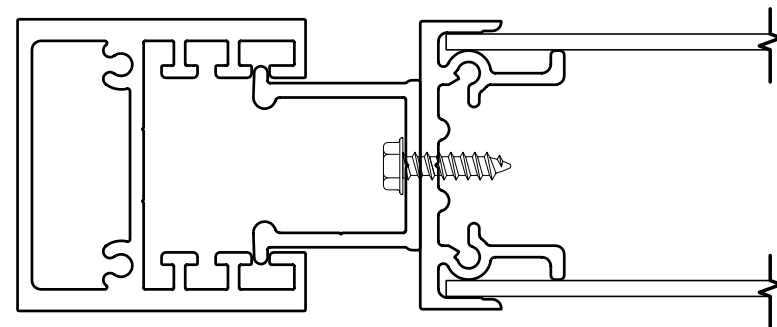

3/4" REVEAL POSITION

SCALE : 3/4" = 1"

FINISH GRADE
OR
TOP OF FOOTING

INSERT FILLER
INTO POST TACK
WELD IT TIGHT UP
AGAINST SIGN BOTTOM
LEAVING 6" OF
FILLER BELOW
GRADE.

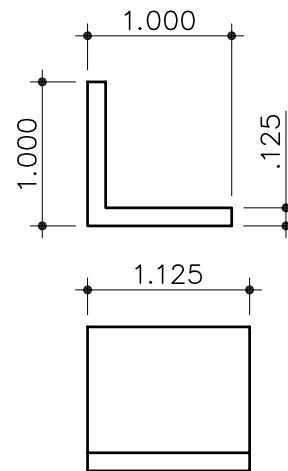

CORNER ANGLE PART #5330

SCALE : 3/4" = 1"

INSTALL REVEAL PIECE
1/8" BELOW TOP OF SIGN
TO ALLOW POST CAP
TO ALIGN FLUSH WITH
TOP OF SIGN

SER 2 - 1100-1

